













## G100

Robinet électronique à 5 voies avec double commande et mélangeur d'eau.  
Équipé d'une bande LED pour faciliter la lecture lors de la sélection de l'eau. Disponible en finitions chrome, satin et noir mat.



# G100

Gamme				
				
G100 ACWG				
G100 CHWG				

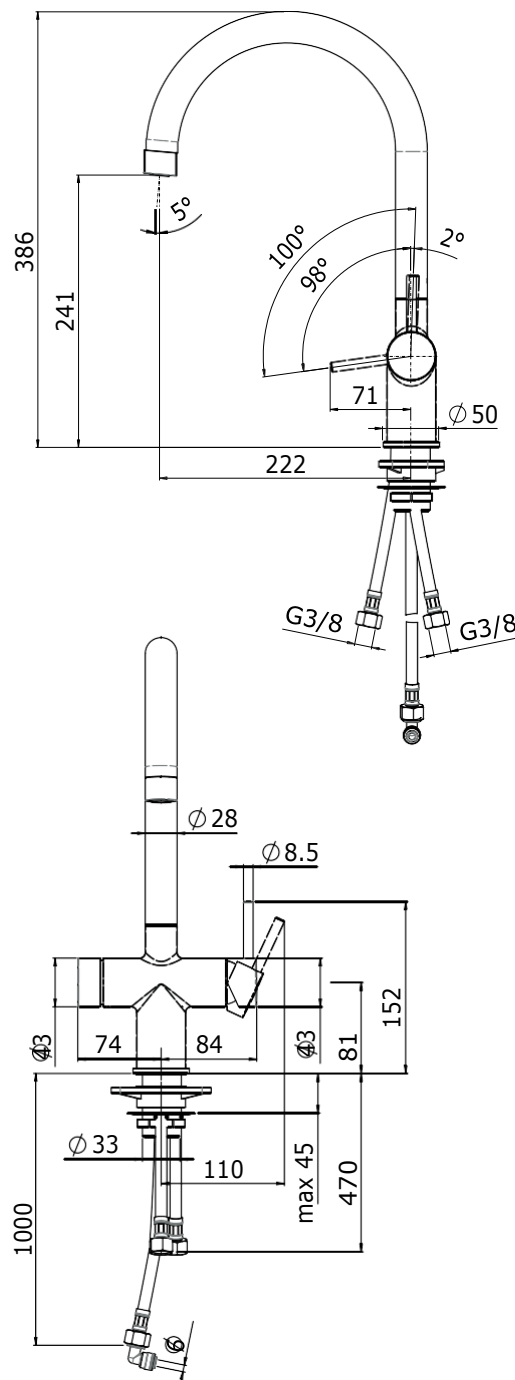
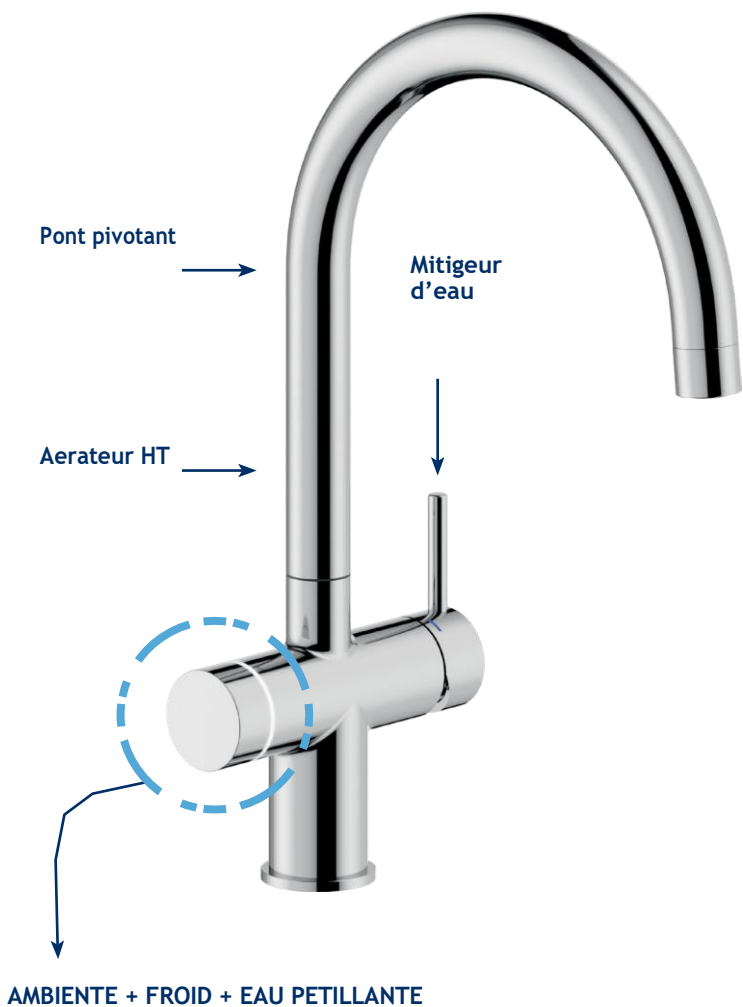

NB: Type John Guest TBD

Informations techniques	
Dimensions	158 L x 386 H mm
Consommation électrique	0,05 W
Matériaux externes	Laiton chromé
Raccords	Type John Guest TBD G3/8