



PLANCHA

Modèle M1000E

CARACTÉRISTIQUES

Puissance: 12kW

- ✓ Haute performance
- ✓ Surface soudée hermétiquement
- ✓ Plaque de 18 mm d'épaisseur.
- ✓ Bain chrome poli miroir dur 50 microns
- ✓ Carrosserie entièrement inox AISI 304
- ✓ Régulation par thermostat indépendant
- ✓ Nettoyage facile sans détergent (pose de glaçons quand température à 80°C)
- ✓ Conçu et fabriqué dans l'UE

OPTIONS :

Rainurage :

1/1 : réf RAIN1/1M1000E

1/2 : réf RAIN1/2M1000E

1/3 : réf RAIN1/3M1000E



Caractéristiques techniques

Tension	230/400 V 3F+N
Fréquence	50/60 Hz
Puissance	12 kW
Zone de cuisson	900x500x18 mm
Température max.	285°C
Tiroir à graisse	2x4L

VUE DE FACE

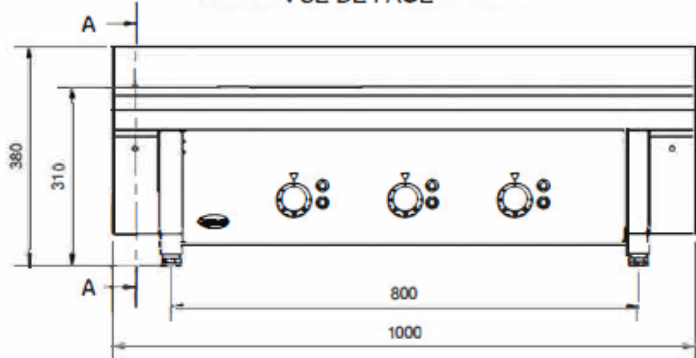

VUE DE CÔTE

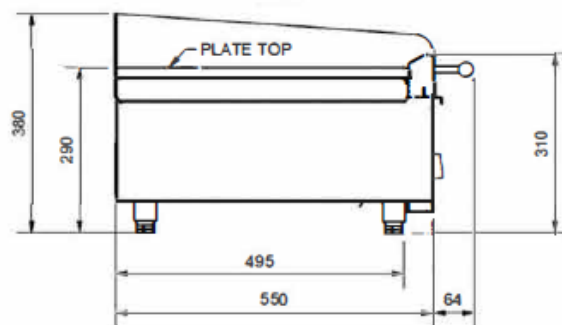

VUE DU DESSUS

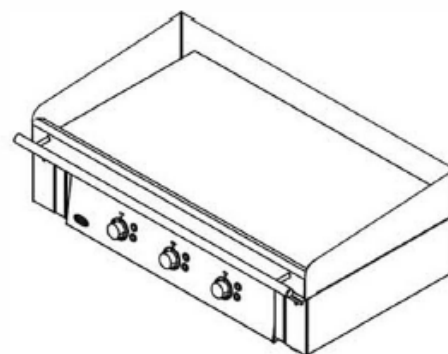
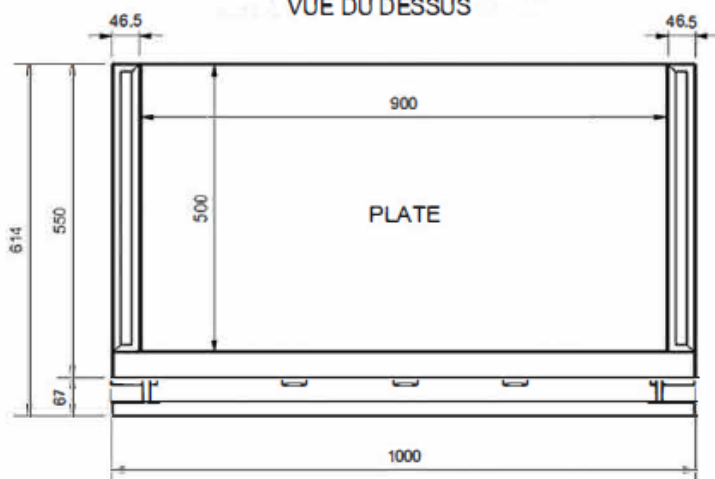

Dimensions extérieures

Largeur	1000 mm
Profondeur	550 mm
Hauteur	380 mm
Poids	112 kg

M1000 C1 avec CLAM

